



RH TEEN

36" GEOMETRIC METAL BRACKET WOOD SHELF

PARTS

- A [1] SHELF
- B [2] BRACKETS (Brackets are sold separately)

NO.	ITEM	DESCRIPTION	QTY.
1		1.5" Screw	4 PCS.
2		1" Screw	4 PCS.
3		Anchor	4 PCS.

ASSEMBLY INSTRUCTIONS

Professional installation recommended

1. Carefully unpack the contents of the carton.
2. Position the shelf on top of the brackets. The back of the shelf should be flush against the wall.
3. Place the shelf on a flat surface, and measure the distance between the predrilled pilot holes on underside of shelf.
This distance will help determine spacing for shelf's brackets on the wall.
4. Using a Phillips screwdriver (not included), affix the shelf to the brackets with 1" screws (2).
5. Mark the centers of the bracket holes onto the wall with a pencil.
6. Insert drywall anchors (3) into wall at marked places (gently tapping until flush with wall). Place both brackets in position on the wall over the inserted anchors, and 1.5" screws (1) with a Phillips screwdriver, pressing firmly to prevent anchor from rotating. Tighten screws until resistance is felt; this will fully expand the anchor.
7. Assembly is complete.

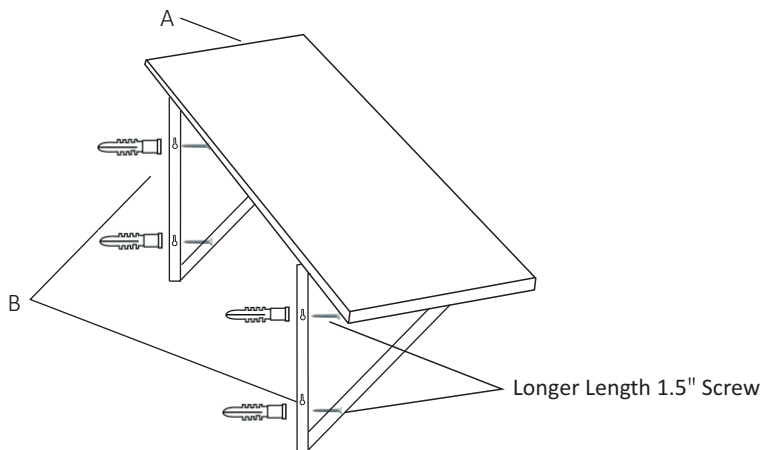
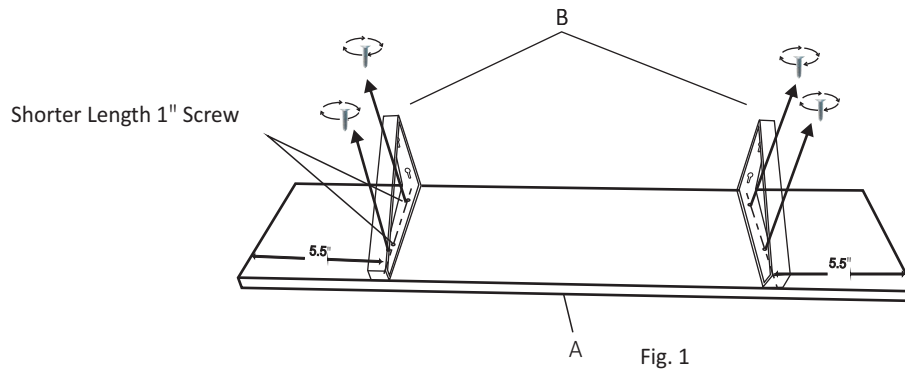

CARE INSTRUCTIONS

1. Clean periodically by wiping the shelf with a dry cloth.
2. Do not use abrasive cleaners, chemical cleaners or metal polishes.

IMPORTANT SAFETY INSTRUCTIONS

1. Professional installation recommended.
2. Do not place heavy objects on the shelf.
3. Never sit on, stand on or apply heavy pressure to the shelf.
4. Recommended maximum loading weight is 36 lbs.