



RHTEEN

VALENTINA TWIN DAYBED INSTRUCTIONS

PARTS INCLUDED

- A [2] SIDE PANEL
- B [1] FRONT PANEL
- C [1] HEADBOARD
- D [4] SLAT
- E [2] PLATFORM PANEL

NO.	ITEM	DESCRIPTION	QTY
1		Allen Key (0.5cm Dia)	1 pc
2		Allen Head Bolt(0.8cm Dia*2.8cm)	4 pcs
3		Thread Rod	4 pcs
4		Curved Washer	4 pcs
5		Lock Washer	4 pcs
6		Nut	4 pcs
7		Spanner Wrench	1 pc
8		Screw (4cm)	8 pcs
9		Screw (3cm)	16 pcs

TOOLS NEEDED

Phillips Head Screwdriver (not include) 

ASSEMBLY INSTRUCTIONS

Bed must be assembled by at least two people.

Please read instruction carefully before assembling bed.

Use the above parts and hardware list to identify each component.

Keep all packing materials until assembly is complete to avoid loss of smaller parts.

1. Stand the Headboard (C) upright and hook the Headboard (C)'s top hook into the Side Panels (A), as shown in Diagram I.
2. Screw the Allen Head Bolts (2) into the Side Panels (A), then stand the Headboard (C) upright and attach the Headboard (C)'s low hook into the Side Panels(A) and tighten with Allen Key (1), as shown in Diagram II.
3. Stand the Front Panel (B) upright and lock the Front Panel (B) & Side Panels (A) with Thread Rod (3), Curved Washer (4), Lock Washer (5) and Nut (6), then tighten with Spanner Wrench (7), as shown in Diagram III.
4. Place the Salt (D) into the cleats on the inside of the Side Panels (B) and Headboard (C), then tighten with Screws (8), as shown in Diagram IV.
6. Lay the Platform Panels (E) flat on the top of the Slats (D), then tighten with Screw (9), as shown in Diagram V.

CARE INSTRUCTIONS

1. Spot clean only with a soft, damp cloth.

Diagram II

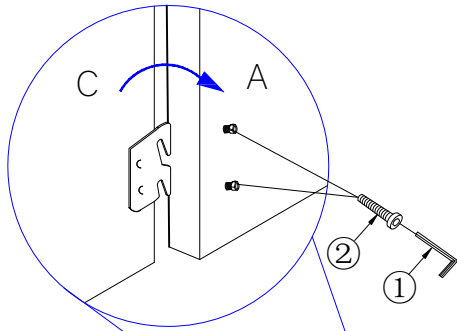

Diagram I

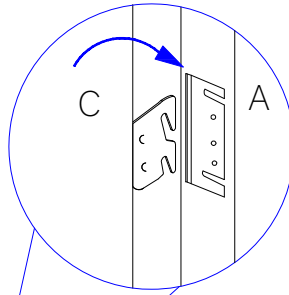

Diagram III

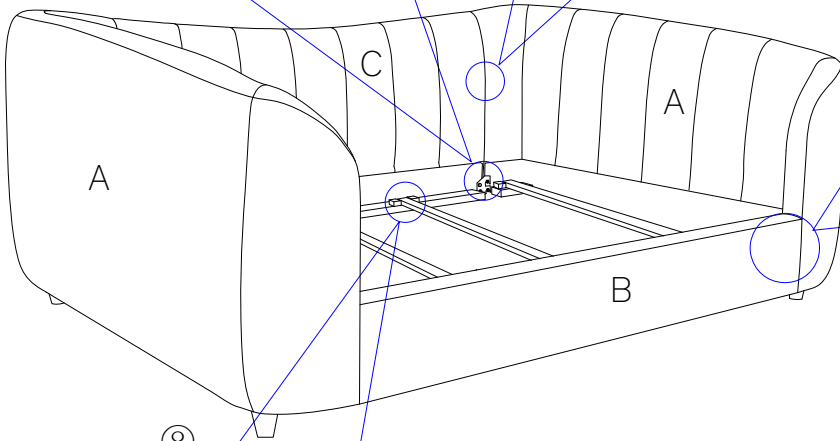
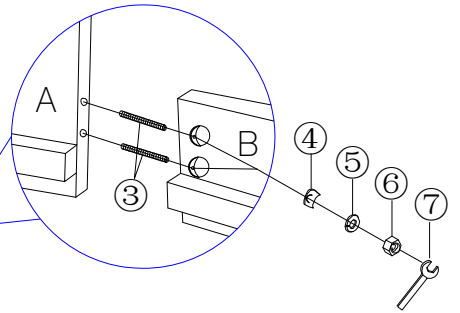

Diagram IV

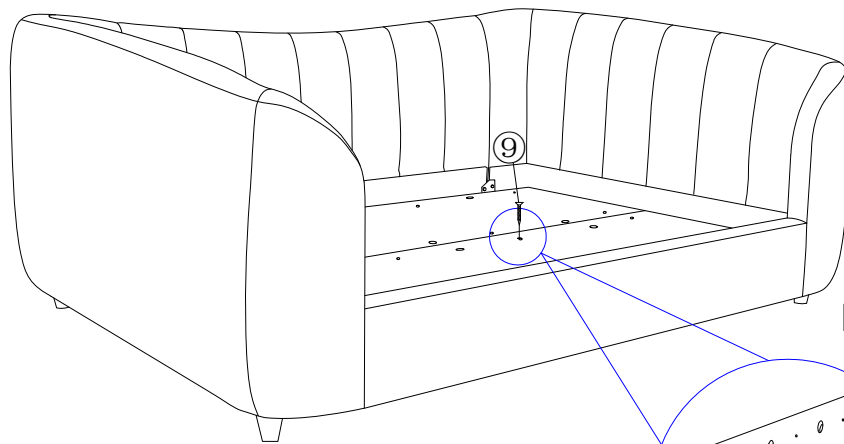
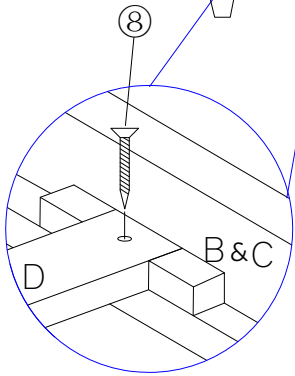

Diagram V

