

# RHTEEN

## GRIER PANEL FULL/ QUEEN BED INSTRUCTIONS

### PARTS INCLUDED

- A [1] HEADBOARD
- B [1] FOOTBOARD
- C [1] LEFT SIDE RAIL
- D [1] RIGHT SIDE RAIL
- E [3] SLATS
- F [3] CENTER LEGS
- G [2] PLATFORM PANELS

### TOOLS NEEDED

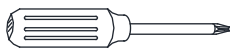

Phillips head screwdriver ( not included)

### ASSEMBLY INSTRUCTIONS:

#### STEP 1:

- Secure the Threaded Rod (4) to the Left/ Right Side Rails (C,D). (Refer to Detail "AA")
- Attach Metal Brackets (10) to the Left/ Right Side Rails (C,D) by Bolts (1), Spring Washers (2), Flat Washers (3), and tighten with Allen Key (8). (Refer to Detail "BB")

NO.	ITEM	DESCRIPTION	QTY.
1		Bolts 5/16" x 1"	8 pcs.
2		Spring Washers 5/16" x 13mm	8 pcs.
3		Flat Washers 5/16" x 19mm	8 pcs.
4		Threaded Rod 5/16" x 3"	4 pcs.
5		Hex Nut 5/16" x 12mm	4 pcs.
6		Curved Slotted Washer 5/16"	4 pcs.
7		Screws 8 x 30 mm	26 pcs.
8		Allen Key 4 mm	1 pc.
9		Hex Wrench 12 mm	1 pc.
10		Metal Bracket	2 pcs.

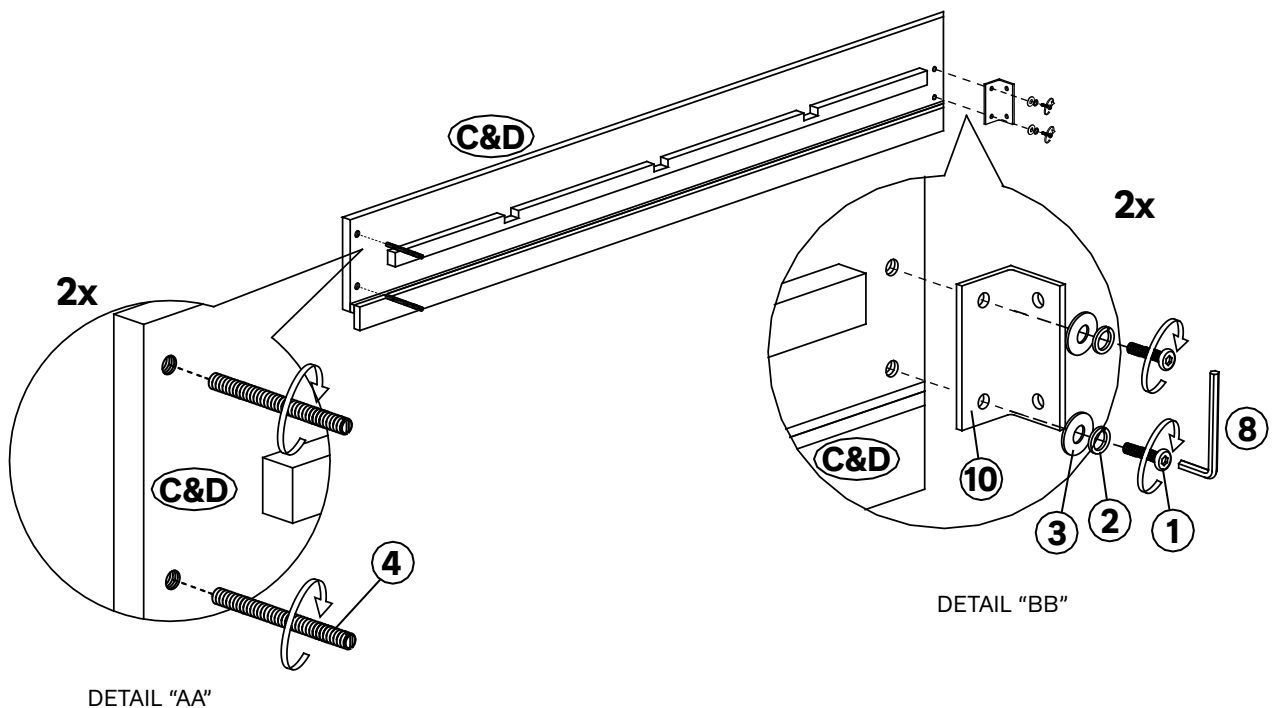

## GRIER PANEL FULL/ QUEEN BED INSTRUCTIONS

### STEP 2:

- Attach the Left/ Right Side Rails (C,D) to the Footboard (B) by using Bolts (1), Spring Washers (2), Flat Washers (3), and tighten with Allen Key (8). (Refer to Detail "CC")

- Raise the Left/ Right Side Rails (C,D) up and place the rod into the Headboard (A) at the bore holes' position, insert Curved Slotted Washer (6) and tighten Hex Nuts (5) with Wrench (9). (Refer to Detail "DD")

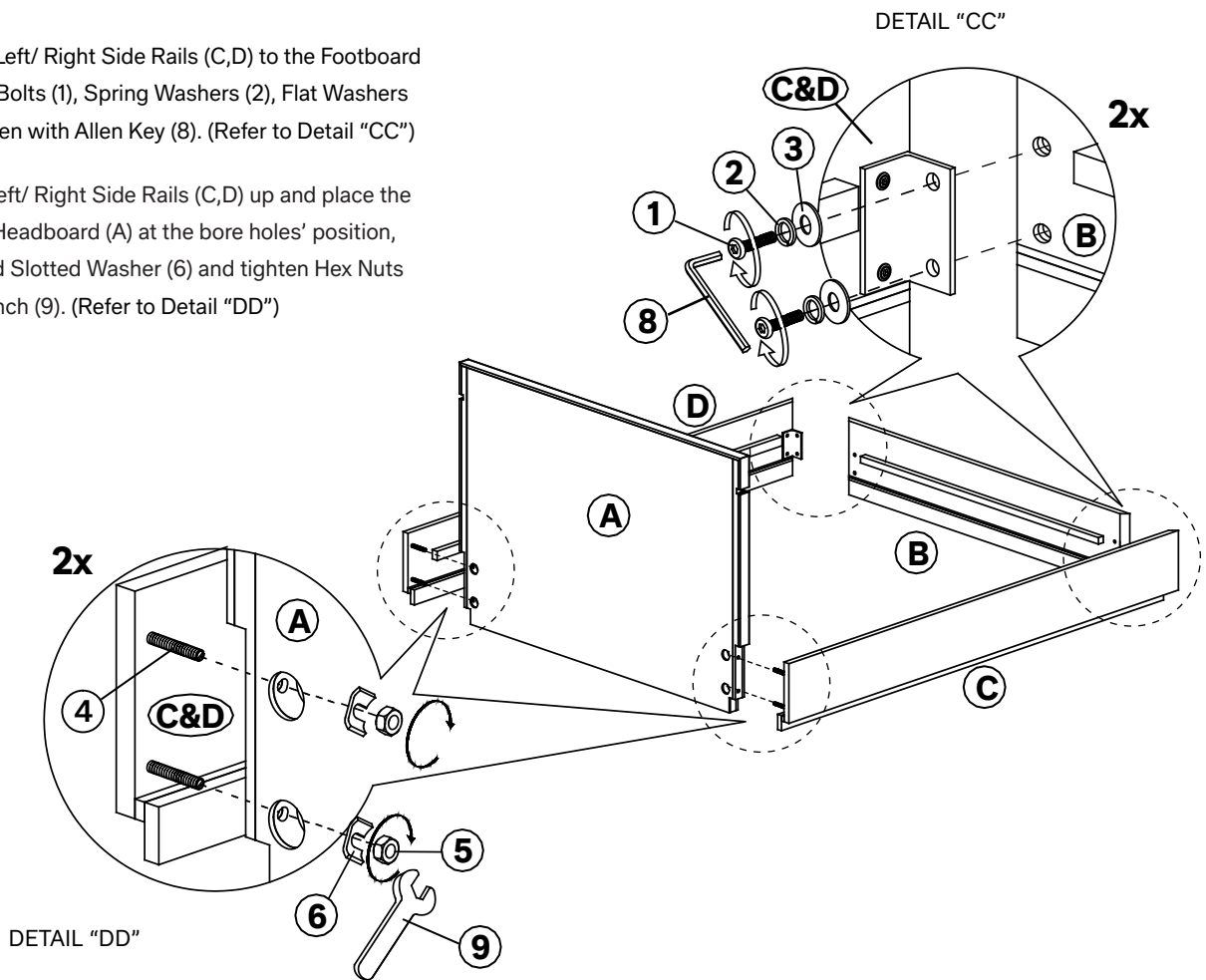

### STEP 3:

Tighten the Support Legs (F) to the bottom of Slats (E).

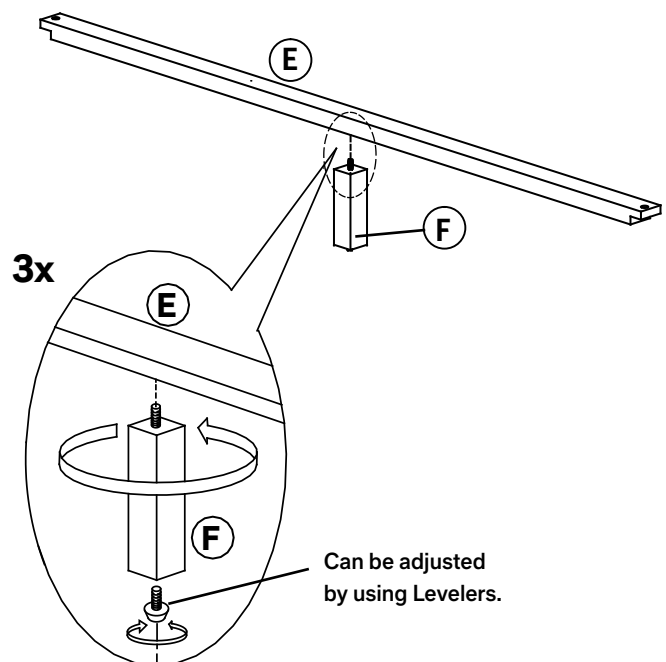

## GRIER PANEL FULL/ QUEEN BED INSTRUCTIONS

### STEP 4:

Lay the Slats (E) in between the Left/ Right Side Rails (C,D), and attach using Qty.6 Screws (7) with Phillip Head Screwdriver.

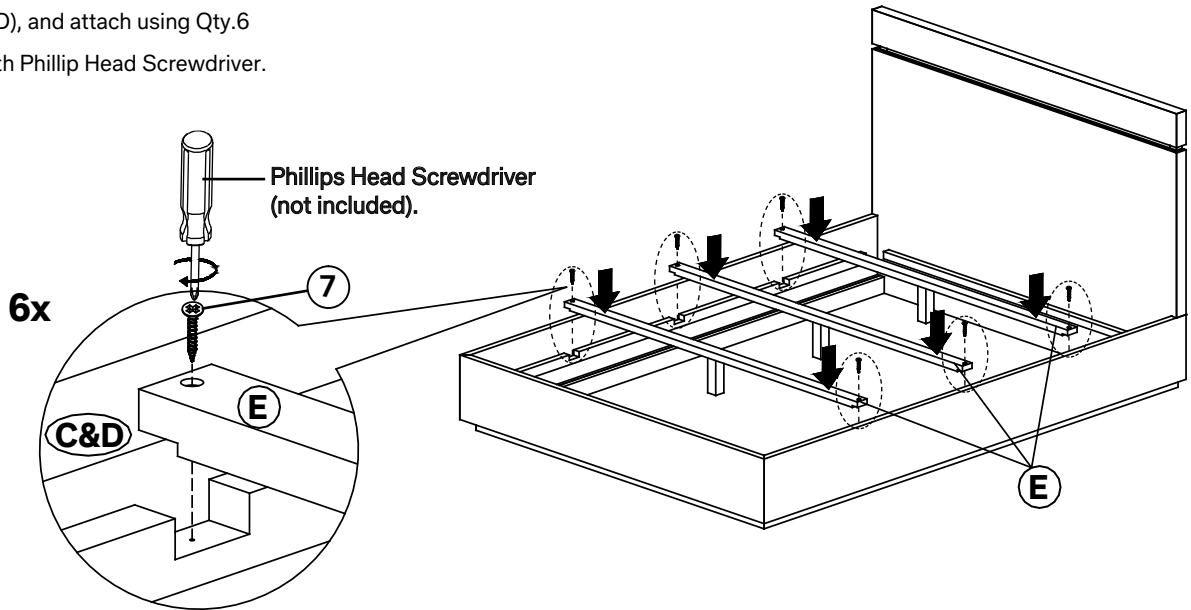

### STEP 5:

Lay the Platform Panels (G) on top of the Slats (E) and attach using Qty.20 Screws (7) with Phillip Head Screwdriver.

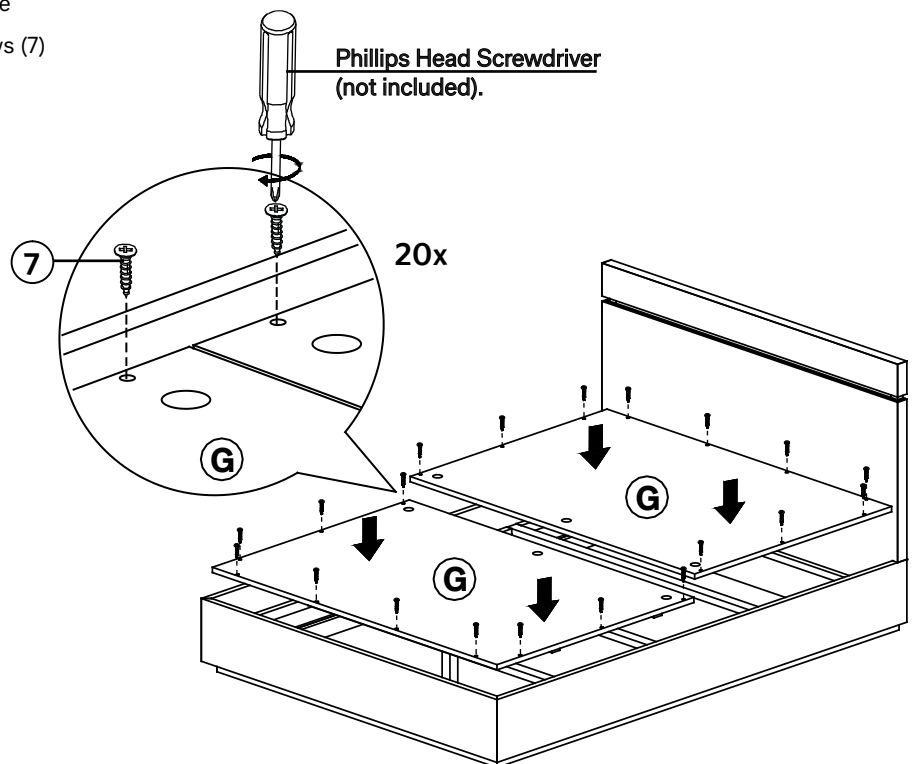

### CARE INSTRUCTIONS:

1. Dust often using a clean, soft, dry lint-free cloth.
2. Blot spills immediately, and wipe with a clean, damp cloth.
3. We do not recommend the use of chemical cleansers, abrasives, or furniture polish on our lacquered finish.